



LT412PRO

# 12 Tonne 4 Post Professional Hoist



**HIGH QUALITY 12 TONNE 4 POST HOIST. MANUFACTURED IN SPAIN, PERFECT FOR COMMERCIAL DEALERSHIPS AND WORKSHOPS.**



## Features:

- › Electro-Hydraulic lifting system.
- › Platform locking system operated automatically by electromagnets.
- › Innovative column design removes longitudinal welds, strengthening the structure.
- › Hydraulic cylinder with valve to control the lowering speed with any weight.
- › Push-button UP and DOWN, and separate ON/OFF switch.
- › Special protection on pulley zones.
- › Smooth platforms.
- › Upper height limit switch.
- › Automatic release of safety wedges when you push the DOWN button.
- › Motor is equipped with a thermal detector to protect against overheating.
- › Homologated and certified product according to the European Machinery Directive 2006/42/CE and Harmonized standard EN 1493:2010.



If you are not 100% satisfied with your equipment, Treadway Equipped will repair, replace or refund the equipment free of charge within the first 100 days.

LT412PRO

# 12 Tonne 4 Post Professional Hoist

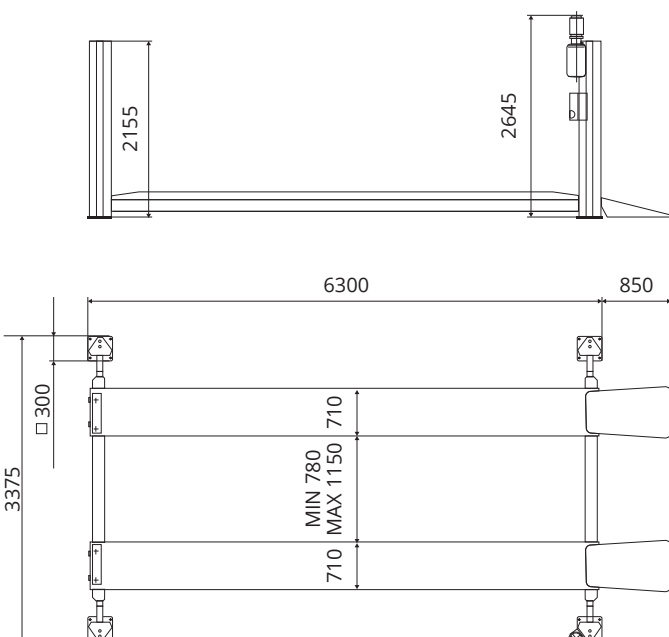

### Features:

- › Electro-Hydraulic lifting system.
- › Platform locking system operated automatically by electromagnets.
- › Innovative column design removes longitudinal welds, strengthening the structure.
- › Hydraulic cylinder with valve to control the lowering speed with any weight.
- › Push-button UP and DOWN, and separate ON/OFF switch.
- › Special protection on pulley zones.
- › Smooth platforms.
- › Upper height limit switch.
- › Automatic release of safety wedges when you push the DOWN button.
- › Motor is equipped with a thermal detector to protect against overheating.
- › Homologated and certified product according to the European Machinery Directive 2006/42/CE and Harmonized standard EN 1493:2010.

### SPECIFICATIONS

|                            |                                  |
|----------------------------|----------------------------------|
| Load capacity              | 12000 kg                         |
| Platforms width            | 710 mm                           |
| Width between columns      | 3265 mm                          |
| Distance between platforms | (min -max) 780- 1150 mm          |
| Drive on height            | 220 mm                           |
| Lifting height             | 1660 mm                          |
| Lifting time               | 65 seconds                       |
| Overall length             | 7150 mm                          |
| Overall width              | 3735 mm                          |
| Motor 4ED0700N             | 3 Phases 230/400 V - 50 Hz. 3 KW |
| Motor 4ED0762N             | 3 Phases 230/400 V - 60 Hz. 3 KW |

**LT412PRO**

**12 Tonne 4 Post Professional Hoist**

High quality 12 Tonne 4 Post Hoist manufactured in Spain, perfect for commercial dealerships and workshops.



**Safety & design**



› **No need for compressed air**  
Does not require compressed air to run



› **Safety**  
Maximum safety system against obstacles



› **Safety**  
Pre-stressed steel wires – high strength and low wear



› **Safety**  
Device allows wires to rest without load, increasing safety and minimising wear



› **Electrical safety**  
Electronically controlled locking system



› **Safety**  
Toe-trapping protection

**Options**

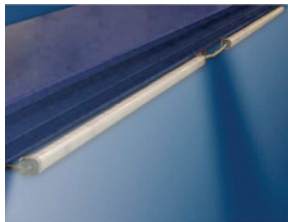

› **Optional**  
Lighting equipment for platforms



› **Optional**  
Tools support



› **Optional**  
Inspection lighting equipment 24V



› **Optional**  
Air and energy supply



› **Optional**  
Scissor jacking beam



› **Optional**  
Exit ramp set



› **Optional**  
Colour customisation when purchased from the factory



OUR PROMISE:

**100**

ONE HUNDRED DAYS  
100% SATISFACTION

If you are not 100% satisfied with your equipment, Treadway Equipped will repair, replace or refund the equipment free of charge within the first 100 days.

**0800 436 436**  
[treadwayequipped.co.nz](http://treadwayequipped.co.nz)